



Garage Door

fitting instructions

Tracked Framed Fitting Instructions V6.1

Warning!



Garage doors are under extreme pressure from the spring system and a poorly installed frame could lead to serious injury if the door comes loose or falls in any way.

Before you start!

Measure

Measure the overall size of the door and frame delivered. Remember that you cannot trim down a steel frame and so you are looking for a brick opening that is slightly bigger than the door and frames overall size. Also check the opening is square and there is the space required inside the garage to ensure that the door and tracks are not impeded.

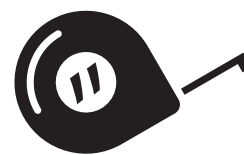

Pack Contents

1x fitting pack containing:

- 6x slotted angled frame fixing brackets
- 1x handle pack (2x if wicket door)
- 18x M8 coach screws
- 33x M8 washers
- 3x keys (6x if wicket door)
- 2x track suspension straps
- 15x Tek screws
- 2x side tracks with black plastic end stops
- Springs (amount depends on door size) -
 - 4x Up to 7'6" wide
 - 6x Over 7'6" wide

1x spring anchor top kit containing:

- 2x wire strap
- 2x plates with 6 adjuster holes
- 2x spring hooks

1x spring anchor bottom kit containing:

- 2x bottom spring anchor plates

Not supplied but required:

- Plastic rawl plugs if fixing to brick
- Light oil for lubricating moving parts

Tools required for installation:



Safety Equipment



Gloves



Goggles

Wear adequate protection when installing

Handy information:

Caution!



Garage doors are heavy and this item must be installed by two people.

Do not!



Do not allow children to assist in the installation, adjustment, or operation of this door. Garage doors can inflict severe injury if not used correctly.

CE Marked



This door is CE marked and comes with a Europe wide 2 year warranty, limitations apply visit **www.wessexdoors.co.uk** and view full terms and conditions.

Warranty



Always ensure the door is correctly adjusted and serviced as failure to do so may invalidate the warranty.

Warning!



Until all parts of the installation are finished, there is a possibility of being locked out, always ensure someone is inside until you have checked the operation of the lock and adjusted as required.

For technical help:

Helpline: 01217 497 977

Email: sales@wessexdoors.co.uk

Website: www.wessexdoors.co.uk

Installation

Offer door up to brickwork, level using wedges and check with spirit level.

Fit the angled frame fixing brackets

Check for suitable fixing point and attach 1x angled frame fixing bracket to the back of the door frame using 1x self drilling tek screw with a washer.

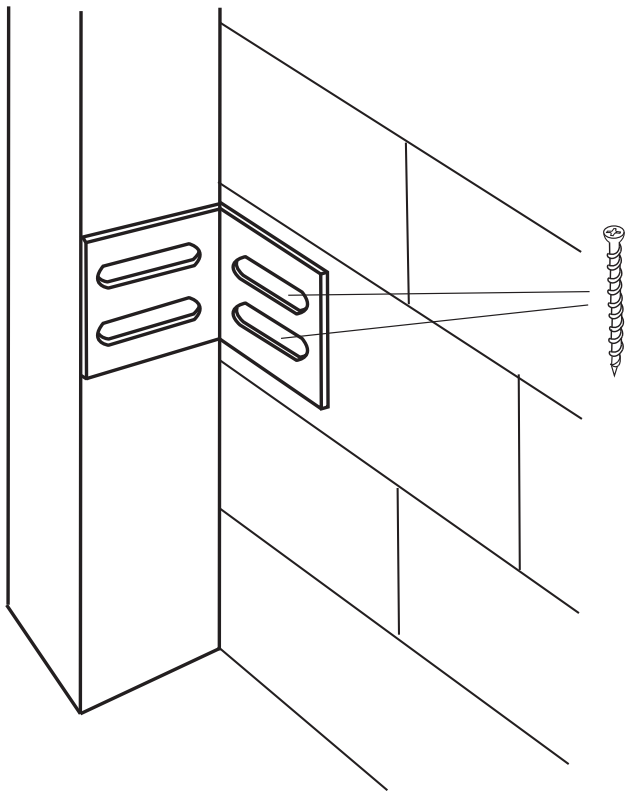

Fix the self drilling tek screw into the steel frame and the M6 50mm coach screw into the brickwork. You will need 10mm rawl plugs - **not supplied**.

Repeat the process so you have at least 3 brackets per side evenly spaced.

Now bolt the brackets to the wall with 50mm coach screws. You will need rawl plugs (**not supplied**) at this stage.



Check!

Ensure the brackets are firmly fixed in place and the door is rigid. Check the levels again and adjust.

Installing the tracks

The tracks install either side at the top, fixed to the back of the frame over the running wheel using 2 x 10 mm self tapping coach screws. The frame has the screw in position, take them out, offer up the tacks and replace the screws. Slide over the hanging straps as shown below.

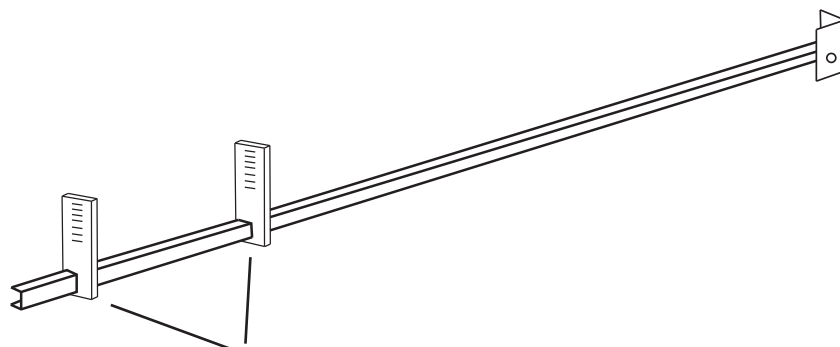

Tip!



Smaller doors will only have 1 hanging strap. Hang from the beams in the garage (cut the straps if required) so the back of the track is 30mm lower than the front. This will stop the door falling too quickly at the start of the downward movement.

Now fit the black end stops to the back of the tracks. Before continuing, run a tape between the tracks at the front and back to ensure they are the same distance apart. Adjust if required.

Once you have completed the above steps, open the door.

Caution!



The door will be heavy because you cannot yet fit the springs and we advise that this is a two man job.

Ensure the wheels are locked into both of the black end stops. If the door is rubbing the frame on one side it is because the tracks are not parallel to the door at a 90 degree angle to each other. Remedy this now. Try measuring the cross measurements of the track from front to back on both sides and ensure they are the same.

Once satisfied you **must** cross brace the hanging strap to control the door sway on opening and closing .

Stretching the springs

With the door in the open position we are ready to install the springs.

Caution!



You must wear gloves and eye protection as you will be stretching the springs.

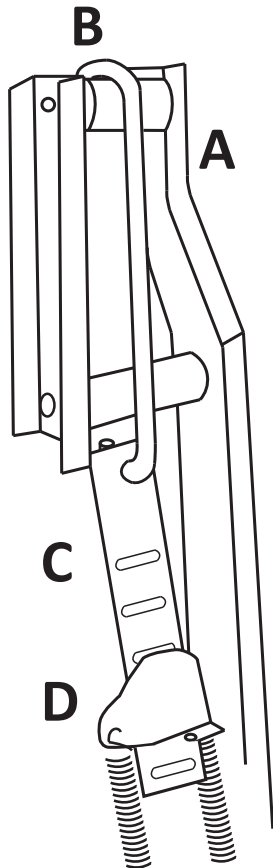

- A** = Lifting Arm
- B** = Hook hanger
- C** = 6 slotted hole plate adjuster
- D** = Top spring anchor bracket
- E** = Bottom spring anchor bracket

The figure left shows the door in the closed position.

First, hook 'B' (hook hanger) over the top of the lifting arm 'A'. You will see where it sits in the groove as shown.

Hook 'C' (slotted hole plate adjuster) onto the bottom of part 'B' as shown. Hook 'D' (top spring anchor bracket) into the second hole from the bottom of the six options.

Now hook one spring onto part 'E' usually closest to the wall as shown and hook onto the pre fitted hook at the bottom of the frame leg as shown.

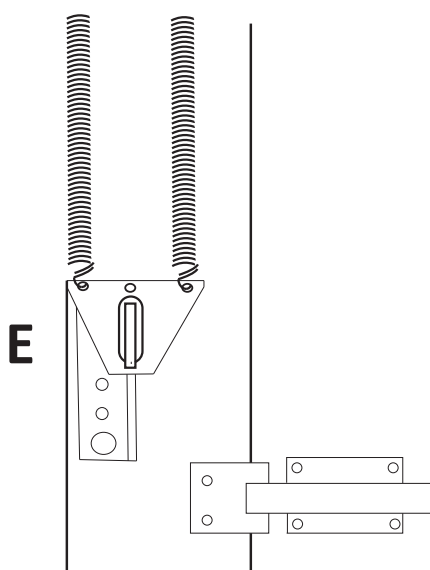

Now stretch the spring upwards and hook onto the corresponding hole in part 'D' ensuring the springs are not crossed. Repeat for all springs. Some heavy doors require 6 springs and the third goes on the front hole in part 'D'. **This may take two persons to hook the springs in place.**

Stretching the springs

Once all located and safe, you can now close the door. Ensure someone is inside to check the locking works correctly. Control the door from the open to the closed position. Do not let go of the door as it may be necessary to move the spring locator and the door may open too fast or too slowly.

Balance the door by moving 'D' position up the scale for a faster opening or down the scale for a slower opening. Always adjust with the door in the open position.

Now fit the lock and adjust latches so they open and close smoothly .

Fitting the outer handle

Fit the outer lock with the Wessex badge to the outside of the door. Fit the inner lock and the moulded fixing using an Alan key and tighten. Check the locking works correctly from the inside by closing the door and opening again.

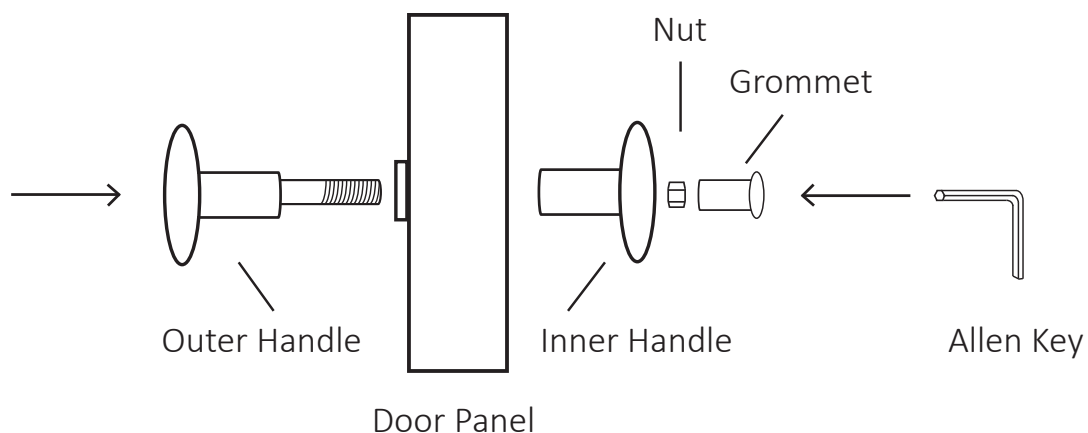

Caution!



Do not do this from the outside as if adjustment is required you may not be able to open the door again.

Finish the door with trim as required.

Automation system

This door can be fitted with an automation system. We recommend a genuine Wessex system as they are tested compatible, however if you should choose another model you must pair a CE marked motor unit that is compatible with the door and ensure it can be issued with a certificate of conformity upon installation.

Final step and door maintenance

The door should be opening and closing correctly. Now oil all moving parts with a light oil including latches. **Do not use grease in the tracks.**

It is important that you check the movement every 3 months and adjust cables latches and springs to ensure a smooth operation.

Customer Satisfaction

We hope you are satisfied with your purchase however if there's some elements of the installation or aftercare you wish to clarify our technical helpline is **01217 497 977**.

Warranty



Your door carries the following warranty:

All moving parts 2 years. Warranty is from the proof of purchase, however if lost we will accept the serial number/date of manufacture as the start of the warranty period.

To claim you must contact the original supplier who will supply the correct information for the claim.

Your product was designed and manufactured in Birmingham Uk , Over 90% of Raw material and pre assembled parts are sourced in the Uk.

Produced in the Uk - Wessex Doors 19 –B35 7AR



EC Declaration of Conformity



We, the Wessex Doors company of the United Kingdom, do hereby declare that the building industry product described in the detail below conforms in all respects and meets all requirements if assembled and maintained in accordance with the installation instructions.

Product Wessex overhead garage door for manual operation

Standard Industrial, commercial and garage doors and gates -
Product standard - Part 1: Products without fire resistance
or smoke control characteristics.

EN 13241-1

EN 12604 Mechanical aspects - requirements

EN 12605 Mechanical aspects - test procedures

We furthermore declare that the technical documents including test certified will be made available to the relevant governing authority upon request.

Authorised persons for the compilation and management of the technical documentation:

The Directors
Wessex Doors
25/06/2013



wessex
DOORS

Wessex Doors, Unit 19, The Fort Industrial Park,
Dunlop Way, Birmingham B35 7AR

Tel: 0121 749 3699

Fax: 0121 748 2677

e-mail: sales@wessexdoors.co.uk

web: www.wessexdoors.co.uk

Wessex Doors reserves the right to alter specifications to design and manufacture without notification. All specifications are correct at time of publication, errors and omissions excepted. Colour samples are, due to the print process, intended as a guide only, please request a sample if unsure.